



RK

Radius - Kelit
Infrastructure

FibreFlex Pro

Product Catalogue

2017.09

FibreFlex Pro

pre-insulated flexible pipe system

A. Product Catalogue

Table of Contents	A0. System description	03
	A1. Pipe products	06
	A1.1. FibreFlex Pro pipe	06
	A1.2. FibreFlex Pro DUO pipe	07
	A2. Coupling connections	08
	A2.1. Outer Sleeve for FibreFlex Pro Press Connectors	09
	A2.2. Polymer Sleeve for FibreFlex Pro Press Connectors	10
	A2.3. FibreFlex Pro Press Weld Adaptor	11
	A2.4. FibreFlex Pro Press Thread Adaptor	12
	A2.5. FibreFlex Pro Press Coupler	13
	A3. Pre-insulated Fittings	14
	A3.1. FibreFlex Pro 90 Degree Bend Pre-Insulated	16
	A3.2. FibreFlex Pro 90 Degree Bend Pre-Insulated DUO	17
	A3.3. FibreFlex Pro T-Branch Pre-Insulated	18
	A3.4. FibreFlex Pro T-Branch Pre-Insulated DUO	20
	A3.5. FibreFlex Pro 90 Degree Bend Building Entry Pre-insulated	21
	A3.6. FibreFlex Pro 90 Degree Bend Building Entry Pre-insulated DUO	22
	A3.7. FibreFlex Pro Y-Connection UNO to DUO Pre-Insulated	23
	A4. Products to resist water ingress and provide heat insulation	24
	A4.1. End Cap Heat Shrink	25
	A4.2. End Cap Heat Shrink DUO	26
	A4.3. Sleeve Heat Shrink	27
	A4.4. Dead End Heat Shrink	28
	A4.5. PUR Liquid Components	29
	A5. Building accessories	30
	A5.1. Wall Sealing Ring	31
	A5.2. Wall Compression Seal 80	32
	A5.3. Wall Compression Seal 40	33
	A5.4. PVC Pipe Sleeve	34
	A6. Pressure Loss	35
	A7. Heat Loss	36

A0. System description

Introduction

FibreFlex Pro is a cutting-edge pre-insulated flexible pipe system for district heating networks, which includes a range of pre-insulated Thermoplastic Reinforced Service (TRS) pipes, specially designed for use within district heating networks operating at temperatures up to 115°C and pressures up to 10 bar.

FibreFlex Pro service pipes have a multilayer pipe wall construction, comprising a cross linked polyethylene PEX-a inner layer (cross linked using the peroxide method), a high modulus Aramid fibre mesh reinforcement layer, an oxygen barrier and additional high temperature resistant thermoplastic adhesive layers used to bond the individual layers to form the composite pipe structure.

This significantly improved structure allows plastic pipes to be used at high operating pressures of up to 10 bar and operating temperatures of up to 115°C, making FibreFlex Pro the ideal alternative pipe solution to rigid pre-insulated steel pipes commonly found in city heat networks.

Cross Linked PEX-a materials have been selected for the inner layer of the FibreFlex service pipes due to their proven reliability. PEX-a has outstanding long term thermal and mechanical properties and excellent corrosion and chemical resistance properties when used in district heating applications.

High modulus Aramid fibre mesh reinforcement is used within the wall of the TRS pipe. It is designed to accommodate the pipe wall stress resulting from internal pressure, enabling the FibreFlex Pro pipe to operate at higher temperatures and internal pressures.

When compared with a conventional flexible pre-insulated plastic pipe solution with equivalent internal diameter, a FibreFlex Pro pipe will have a reduced pipe wall thickness and external diameter and in addition will be able to operate at a higher temperatures and pressures due to the Aramid Fibre mesh reinforcement. This reduced pipe wall thickness and external diameter result in a FibreFlex Pro pipe that is more flexible to install, significantly increasing its range of use for district heating applications.

Technical Specification

FibreFlex Pro pipe is designed for variable operation temperature profile with maximum 115°C peak operational temperature (class C according to OFI CERT ZG 200-2) and 10 bar maximum operating pressure.

Max peak operating temperature: 115 °C

Max operating pressure: 10 bar

Thermal insulation

FibreFlex Pro pipes are continuously insulated during the manufacturing process using a CFC free bonded polyurethane foam, which has an outstanding thermal conductivity value of $\leq 0.021 \text{ W/mK}$ at +50 °C.

As the insulation layer has a lower thermal conductivity than conventional pre-insulated steel pipes ($\lambda=0.027 \text{ W/mK}$), in diameters up to 80 mm, FibreFlex Pro heat loss is lower than insulation series S3 pipes and in larger diameters, FibreFlex Pro heat loss is lower than series S2 pipes.

Design

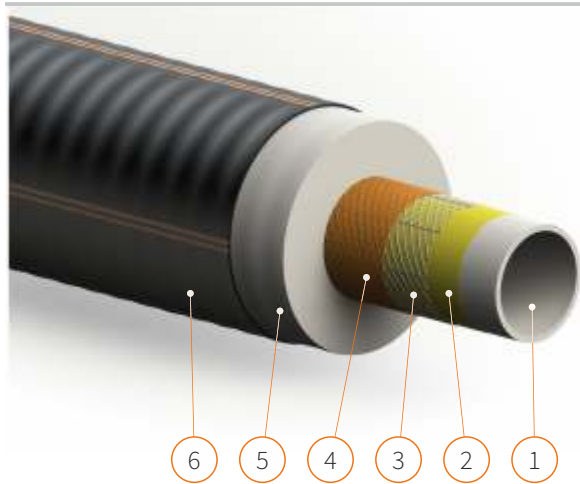

1. PEXa liner
2. High temperature adhesive
3. Aramid fibre mesh
4. Service pipe jacket with oxygen barrier
5. Polyurethane foam
6. Diffusion barrier jacket

Applications

FibreFlex Pro is a flexible pre-insulated TRS pipe system with a peak operating temperature of 115°C and 10 bar design pressure. A range of service pipe diameters from 50 mm to 160 mm are available.

FibreFlex Pro is an ideal solution for:

- Biomass district heating networks
- Elevated-temperature city heat networks
- High-pressure city heat networks
- High-pressure heating networks supplying high buildings
- High-pressure heating networks in hilly areas
- Special applications at operating temperatures up to 115°C (peak) and operating pressures up to 10 bar.

System advantages

The FibreFlex Pro pipe system offers increased flexibility, simplifying the design and installation of the district heating network, especially where the pipe is to be installed in trenches with existing service pipes, or where the pipe has to be routed around existing obstacles, such as trees or buildings.

Compared with conventional rigid steel pre-insulated pipes, FibreFlex Pro offers very quick and easy installation. Additionally FibreFlex Pro pipes are designed and installed without the requirement for complex thermal expansion loops or thermal compensators, resulting in a more cost effective and efficient system.

FibreFlex Pro pipes are delivered to the installation site in long continuous lengths either as a coil or on a drum. Pipes can be supplied cut to the required length, significantly reducing both on-site installation time and the number of joints required to complete the system. The FibreFlex Pro compression jointing system overcomes the need to employ qualified on-site welding techniques normally associated with rigid district heating systems. These longer continuous flexible pipe lengths, combined with an easy to install non-welded fittings solution, enables FibreFlex Pro pipes to be installed using narrow trenching techniques, offering significant on-site installation time and cost savings.

Service life

The FibreFlex Pro pipe system is designed for a 30 year minimum service life with variable temperature profile class C according to OFI CERT ZG 200-2 with maximum 115°C peak temperature and a maximum operating pressure 10 bar.

Where FibreFlex Pro pipelines are operated at temperatures and pressures lower than their design maximum, the service life of these pipe systems can be extended.

Pressure limits

For continuous operating temperature applications, maximum operating service pressure of the FibreFlex Pro pipe system is dependent on temperature and required minimum service life.

Table A0 identifies the relationship between service life, operating pressure and temperature for FibreFlex Pro pipes.

Table A0

Continuous operating temperature, °C	Service coefficient, C	Pressure, bar					
		1 year	10 years	15 years	20 years	25 years	50 years
80	1.5	19.8	15.7	15.1	14.7	14.4	13.4
85	1.5	18.6	14.6	14.0	13.6	13.3	12.4
90	1.5	17.5	13.5	12.9	12.5	12.2	
95	1.5	16.3	12.4	11.9	11.5	11.2	
100	1.5	15.1	11.3	10.8	10.4		
105	1.5	13.9	10.3	9.7	9.4		
110	1.5	12.7					
115	1.3	13.2					

* according to OFI ZG 200-2 technical specification service coefficient C shall be equal to 1.5 for the design temperatures, 1.3 for maximum operating temperature and 1 for malfunction temperature

Approvals

FibreFlex Pro pipe systems are manufactured in accordance with OFI CERT ZG 200-2 Class C Technical Specification.

A1. Pipe products

A1.1. FibreFlex Pro pipe

General

Max. operating temperature (peak):	+115°C
Max. operating pressure:	10 bar
Thermal conductivity of PUR insulation:	≤ 0.021 W/mK at +50°C

Design

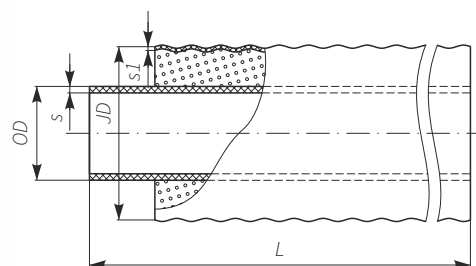

Overview

Table A1.1

Pos	Item	OD×s, mm	JD, mm	Est. Weight, kg/m	Min bending radius, L, m	Max length in coil, L, m	Art.-No.
1	50/111	49.4×3.6	111	1.97	0.9	410	200100050111
2	63/126	58.5×4.0	126	2.38	1.0	300	200100063126
3	75/142	69.5×4.6	142	2.94	1.1	225	200100075142
4	90/162	84.0×6.0	162	4.02	1.2	149	200100090162
5	110/182	101.0×6.5	182	4.99	1.3	86	200100110182
6	125/202	116.0×6.8	202	6.02	1.4	80	200100125202
7	140/202	127.0×7.1	202	6.30	1.4	80	200100140202
8	160/225*	144.0×7.5	225	7.68	1.6	36	200100160225

* will be available soon

A1.2. FibreFlex Pro DUO pipe

General

Max. operating temperature (peak):	+115°C
Max. operating pressure:	10 bar
Thermal conductivity of PUR insulation:	≤ 0.021 W/mK at +50°C

Design

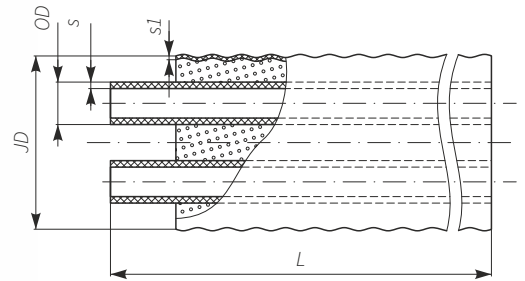

Overview

Table A1.2

Pos	Item	OD×s, mm	JD, mm	Est. Weight, kg/m	Min bending radius, m	Max length in coil, m	Art.-No.
1	50+50/162	49.4×3.6	162	3.55	1.2	149	203100050162
2	63+63/182	58.5×4.0	182	4.53	1.3	86	203100063182
3	75+75/202	69.5×4.6	202	5.74	1.4	80	203100075202

* will be available soon

A2. FibreFlex Press Connectors

Overview

FibreFlex Pro pipes are connected using steel FibreFlex Pro compression fittings (Press connectors). A hydraulic press tool is used to fit the press connector onto the pipe, resulting in a joint which is fully end load bearing in service and which cannot be removed from the pipe.

FibreFlex Pro connectors consists of three parts:

- inner steel coupler;
- polymer sleeve;
- outer steel sleeve.

The installation of the press connector does not require the FibreFlex Pro pipe end to be expanded before placing the steel insert into the pipe; polymer sleeve is compressed between steel outer sleeve and pipe's outer surface, which provides required compression of FibreFlex Pro carrier pipe for reliable connection. For diameters up to and including 110 mm, industry standard press tools may be used when installing FibreFlex Pro press connectors to FibreFlex Pro pipes. For diameters 50-110 and 125-160mm, Radius-Kelit press tools are available.

When insulating the FibreFlex Pro press couplers, heat shrink insulation sleeves shall be used.

Types of coupling connections

Table A2

Name	Purpose	Description
FibreFlex Pro Press Weld Adaptor	for connecting welded steel pipes to FibreFlex pipes	A2.3
FibreFlex Pro Press Thread Adaptor	for connecting threaded pipes to FibreFlex pipes	A2.4
FibreFlex Pro Press Coupler	for the straight connection of two FibreFlex pipes	A2.5

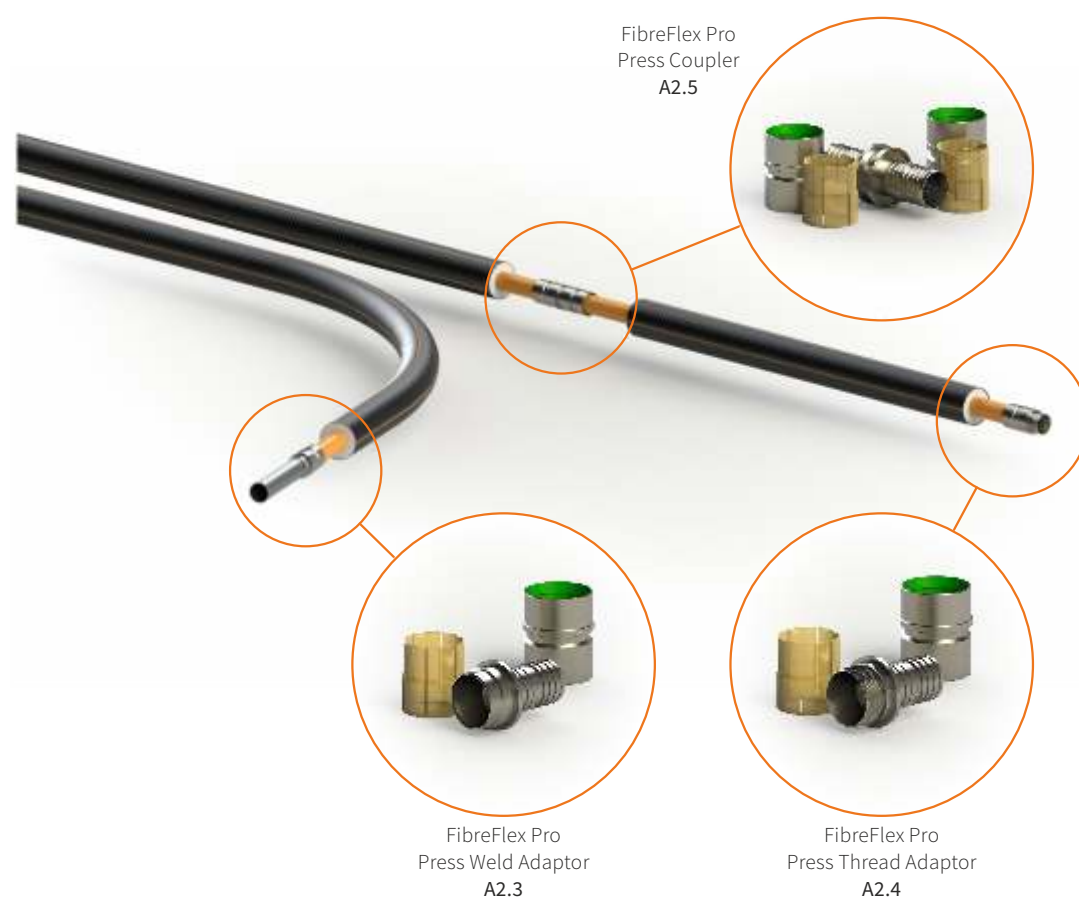

A2.1. Outer Sleeve for FibreFlex Pro Press Connectors

General

Application: used in conjunction with all FibreFlex Pro connectors

Material: steel (stainless steel available to special order)

Design

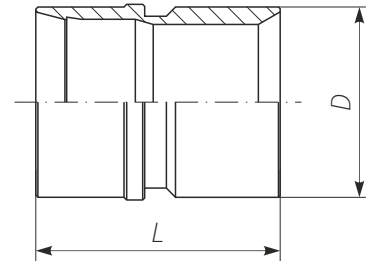

Overview

Table A2.1

Pos	Item	D, mm	L, mm	Weight, kg
1	50	74	95	0.72
2	63	74	113	0.74
3	75	90	128	1.23
4	90	108	135	2.32
5	110	130	145	2.90
6	125	148	155	3.80
7	140	157	172	4.20
8	160	177	172	5.10

Note

Table A2.1 is for information only; (outer sleeves cannot be ordered separately).

A2.2. Polymer Sleeve for FibreFlex Pro Press Connectors

General

Application: used in conjunction with all FibreFlex Pro connectors

Material: high temperature polymer

Design

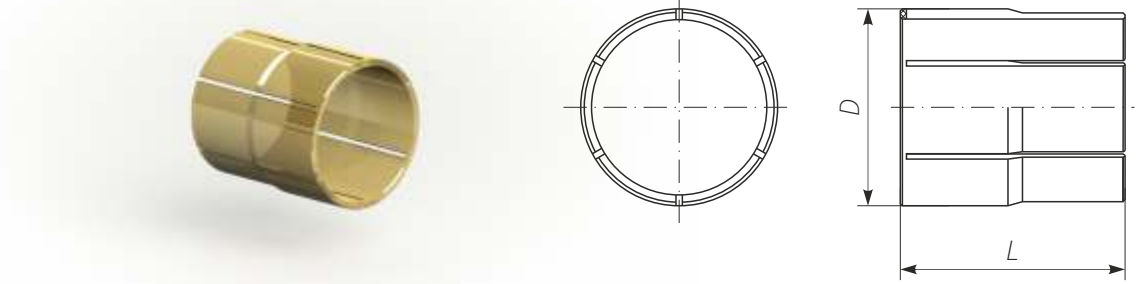

Overview

Table A2.2

Pos	Item	D, mm	L, mm	Weight, kg	Art.-No.
1	50	59	70	0.056	210002000050
2	63	69	88	0.075	210002000063
3	75	81	103	0.108	210002000075
4	90	96	110	0.145	210002000090
5	110	115	120	0.219	210002000110
6	125	132	145	0.317	210002000125
7	140	143	150	0.343	210002000140
8	160	161	150	0.409	210002000160

Note

Table A2.2 is for information only; (polymer sleeves cannot be ordered separately).

A2.3. FibreFlex Pro Press Weld Adaptor

General

Application: to provide a weld connection to FibreFlex Pro pipe

Material: steel (stainless steel available to special order)

Design

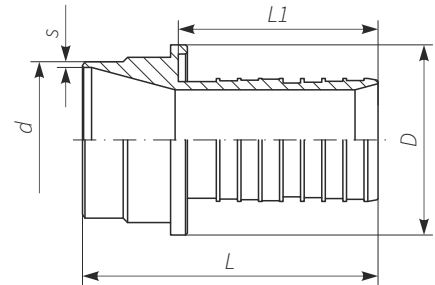

Overview

Table A2.3

Pos	Item	d×s, mm	D, mm	L, mm	L1, mm	Weight, kg	Art.-No.
1	50/DN40	48.3×3.2	74	115	70	1.64	213002050040
2	63/DN50	60.3×3.2	74	130	92	1.67	213002063050
3	75/DN65	76.1×3.2	90	153	108	2.70	213002075065
4	90/DN80	88.9×3.2	108	168	113.5	4.65	213002090080
5	110/DN100	114.3×3.6	130	188	127	6.30	213002110100
6	125/DN125	139.7×3.6	148	195	139	7.90	213002125125
7	140/DN125	139.7×3.6	157	218	155	9.80	213002140125
8	160/DN150	168.3×4.0	177	232	155	12.64	213002160150

A2.4. FibreFlex Pro Press Thread Adaptor

General

Application: to connect threaded pipes to FibreFlex Pro pipe

Material: steel (stainless steel available to special order)

Design

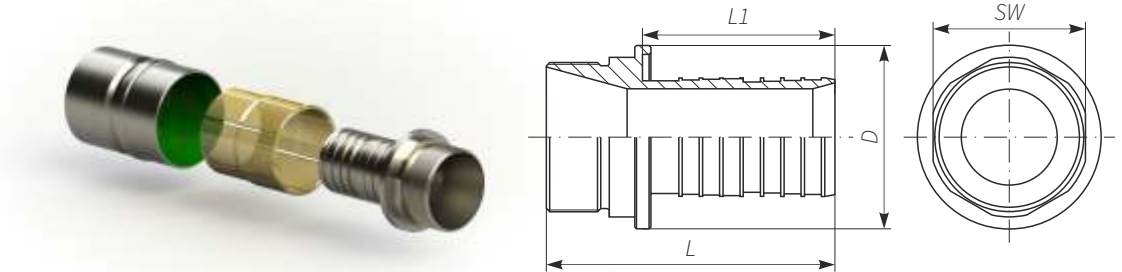

Overview

Table A2.4

Pos	Item	SW, mm	D, mm	L, mm	L1, mm	Weight, kg	Art.-No.
1	50/1½"	46	74	115	70	1.57	215002050112
2	63/2"	60	74	140	92	1.74	215002063200
3	75/2½"	70	90	162	108	2.71	215002075212
4	90/3"	90	108	170	113.5	4.47	215002090300
5	110/4"	110	130	205	127	6.78	215002110400
6	125/5"	120	148	219	139	9.47	215002125500
7	140/5"	130	157	243	155	10.75	215002140500
8	160/6"	150	177	236	155	12.59	215002160600

A2.5. FibreFlex Pro Press Coupler

General

Application: to connect FibreFlex Pro pipe to FibreFlex Pro - straight connection

Material: steel (stainless steel available special order)

Design

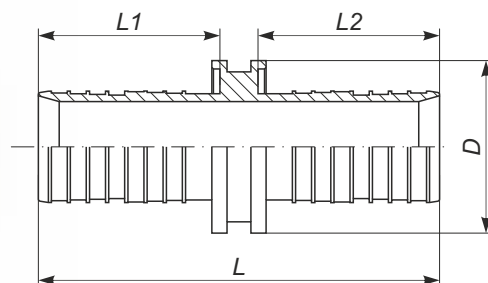

Overview

Table A2.5

Pos	Item	D, mm	L, mm	L1, mm	L2, mm	Weight (incl. Outer Sleeves), kg	Art.-No.
Straight							
1	50/50	74	162	70	70	2.58	211002050050
2	63/63	74	206	92	92	2.82	211002063063
3	75/75	90	241	108	108	4.53	211002075075
4	90/90	108	251	113.5	113.5	7.48	211002090090
5	110/110	130	279	127	127	9.99	211002110110
6	125/125	148	318	139	139	14.15	211002125125
7	140/140	157	360	155	155	17.21	211002140140
8	160/160	177	360	155	155	21.03	211002160160
Reduced							
9	63/50	74	197	92	70	2.94	211002063050
10	75/63	90	240	108	92	4.67	211002075063
11	90/75	108	261	113.5	108	6.85	211002090075
12	110/90	130	295	127	113.5	10.62	211002110090
13	125/110	148	336	139	127	14.60	211002125110
14	140/125	157	369	155	139	18.10	211002140125
15	160/140	177	390	155	155	21.32	211002160140

A3. Pre-insulated fittings

Overview

A range of pre-insulated steel fittings are available which terminate with a pre-welded FibreFlex Pro Press Weld Adaptor; this enables a connection to be made to the FibreFlex Pro pipe without the need for on-site welding.

When insulating the connection between the FibreFlex Pro pipe and the pre-insulated connector, an Insulation Sleeve Heat Shrink should be used. Additional heat shrink bands installed above the ends of Sleeve Heat Shrink provide increased leakage protection.

Types pre-insulated connectors

ofTable A3

Name	Purpose	Description
FibreFlex Pro 90 Degree Bend Pre-Insulated	for short radius bends that cannot be achieved with the minimum bending radius of FibreFlex Pro pipes	A3.1
FibreFlex Pro 90 Degree Bend Pre-Insulated DUO		A3.2
FibreFlex Pro T-Branch Pre-Insulated	for branch connections from FibreFlex Pro pipes	A3.3
FibreFlex Pro T-Branch Pre-Insulated DUO		A3.4
FibreFlex Pro 90 Degree Bend Building Entry Pre-Insulated	for FibreFlex Pro pipeline building bottom entry	A3.5
FibreFlex Pro 90 Degree Bend Building Entry Pre-Insulated DUO		A3.6
FibreFlex Pro Y-connector UNO to DUO Pre-Insulated	for connecting FibreFlex Pro DUO pipe with two single FibreFlex Pro pipes	A3.7



A3.1. FibreFlex Pro 90 Degree Bend Pre-Insulated

General

Application:	for short radius bends in FibreFlex Pro pipelines
Service pipe:	steel ST 37.0
Insulation:	foamed polyurethane (PUR)
Jacket pipe:	HD-PE
Thermal conductivity:	≤ 0.027 W/mK at 50°C

Design

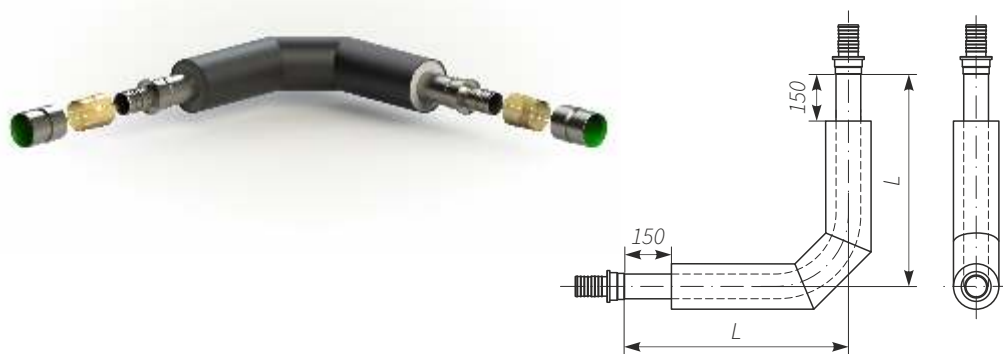

Overview

Table A3.1

Pos	Item	L, mm	Weight, kg	Art.-No.
1	50/110	500	7.09	237102050050
2	63/125	500	7.86	237102063063
3	75/140	500	10.08	237102075075
4	90/160	500	14.80	237102090090
5	110/180	500	18.70	237102110110
6	125/200	1000	36.20	237102125125
7	140/200	1000	40.00	237102140140
8	160/225	1000	49.03	237102160160

A3.2. FibreFlex Pro 90 Degree Bend Pre-Insulated DUO

General

Application:	for short radius bends in FibreFlex Pro DUO pipelines
Service pipe:	steel ST 37.0
Insulation:	foamed polyurethane (PUR)
Jacket pipe:	HD-PE
Thermal conductivity:	≤ 0.027 W/mK at 50°C

Design

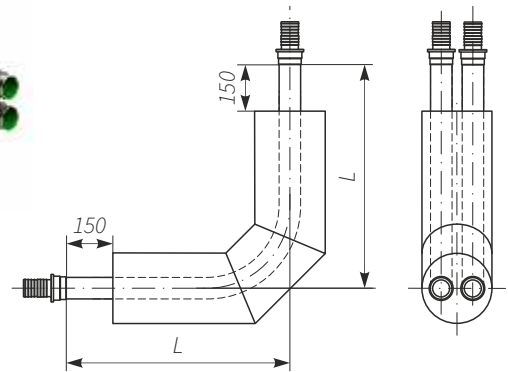

Overview

Table A3.2

Pos	Item	L, mm	Weight, kg	Art.-No.
4	50+50/160	500	11.54	238102050050
5	63+63/180	500	15.17	238102063063
6	75+75/200	500	19.06	238102075075

A3.3. FibreFlex Pro T-Branch Pre-Insulated

General

Application:	for branch connections in FibreFlex Pro pipelines
Service pipe:	steel ST 37.0
Insulation:	foamed polyurethane (PUR)
Jacket pipe:	HD-PE
Thermal conductivity:	≤0.027 W/mK at 50°C

Design

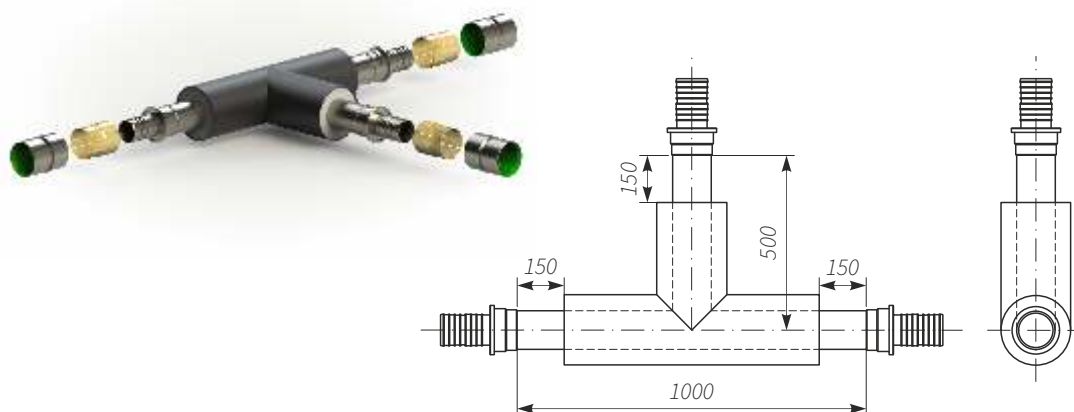

Overview

Table A3.3

Pos	Service pipe dimensions	Jacket pipe dimensions	Weight, kg	Art.-No.
1	50/50/50	110/110/110	10.90	230102040404
2	63/50/63	125/110/125	13.20	230102050405
3	63/63/63	125/125/125	14.40	230102050505
4	75/50/75	140/110/140	16.60	230102060406
5	75/63/75	140/125/140	17.80	230102060506
6	75/75/75	140/140/140	19.50	230102060606
7	90/50/90	160/110/160	20.80	230102070407
8	90/63/90	160/125/160	22.00	230102070507
9	90/75/90	160/140/160	23.70	230102070607
10	90/90/90	160/160/160	25.80	230102070707
11	110/50/110	180/110/180	26.60	230102080408
12	110/63/110	180/125/180	27.80	230102080508
13	110/75/110	180/140/180	29.50	230102080608
14	110/90/110	180/160/180	31.60	230102080708
15	110/110/110	180/180/180	34.50	230102080808
16	125/50/125	200/110/200	33.90	230102090409
17	125/63/125	200/125/200	35.00	230102090509
18	125/75/125	200/140/200	36.70	230102090609
19	125/90/125	200/160/200	38.80	230102090709
20	125/110/125	200/180/200	41.70	230102090809
21	125/125/125	200/200/200	45.40	230102090909
22	140/50/140	200/110/200	34.10	230102100410
23	140/63/140	200/125/200	35.30	230102100510
24	140/75/140	200/140/200	37.00	230102100610
25	140/90/140	200/160/200	39.10	230102100710

Table A3.3 (continuation)

Pos	Service pipe dimensions	Jacket pipe dimensions	Weight, kg	Art.-No.
26	140/110/140	200/180/200	42.00	230102100810
27	140/125/140	200/200/200	45.60	230102100910
28	140/140/140	200/200/200	45.80	230102101010
29	160/50/160	225/110/225	44.10	230102110411
30	160/63/160	225/125/225	45.20	230102110511
31	160/75/160	225/140/225	46.90	230102110611
32	160/90/160	225/160/225	49.00	230102110711
33	160/110/160	225/180/225	51.90	230102110811
34	160/125/160	225/200/225	55.60	230102110911
35	160/140/160	225/200/225	55.70	230102111011
36	160/160/160	225/225/225	60.70	230102111111

A3.4. FibreFlex Pro T-Branch Pre-Insulated DUO

General

Application:	for branch connections in FibreFlex Pro DUO pipelines
Service pipe:	steel ST 37.0
Insulation:	foamed polyurethane (PUR)
Jacket pipe:	HD-PE
Thermal conductivity:	≤ 0.027 W/mK at 50°C

Design

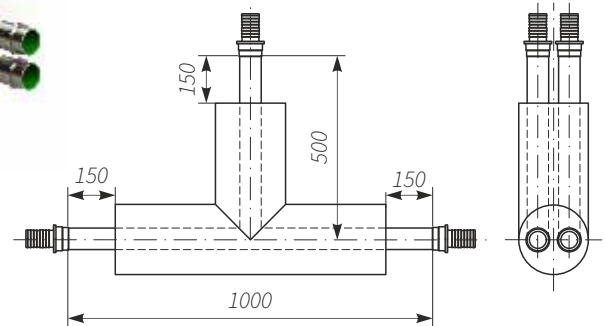

Overview

Table A3.4

Pos	Service pipe dimensions	Jacket pipe dimensions	Weight, kg	Art.-No.
1	2 × 50/50/50	160/160/160	21.10	233102040404
2	2 × 63/50/63	180/160/180	25.80	233102050405
3	2 × 63/63/63	180/180/180	28.10	233102050505
4	2 × 75/50/75	200/160/200	32.40	233102060406
5	2 × 75/63/75	200/180/200	34.80	233102060506
6	2 × 75/75/75	200/200/200	38.10	233102060606

A3.5. FibreFlex Pro 90 Degree Bend Building Entry Pre-insulated

General

Application:	for FibreFlex Pro pipeline building entry
Service pipe:	steel ST 37.0
Insulation:	foamed polyurethane (PUR)
Jacket pipe:	HD-PE
Thermal conductivity:	≤0.027 W/mK at 50°C

Design

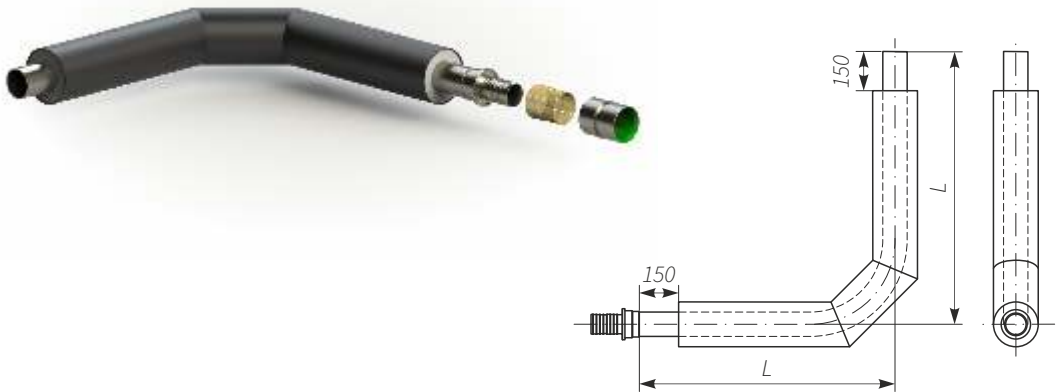

Overview

Table A3.5

Pos	Item	L, mm	Weight, kg	Art.-No.
1	50/110	1000	10.80	235102050050
2	63/125	1000	13.60	235102063063
3	75/140	1000	17.40	235102075075
4	90/160	1000	21.40	235102090090
5	110/180	1000	29.70	235102110110
6	125/200	1000	37.00	235102125125
7	140/200	1000	37.20	235102140140
8	160/225	1000	48.70	235102160160

A3.6. FibreFlex Pro 90 Degree Bend Building Entry Pre-insulated DUO

General

Application:	for FibreFlex Pro DUO pipeline building entry
Service pipe:	steel ST 37.0
Insulation:	foamed polyurethane (PUR)
Jacket pipe:	HD-PE
Thermal conductivity:	≤ 0.027 W/mK at 50°C

Design

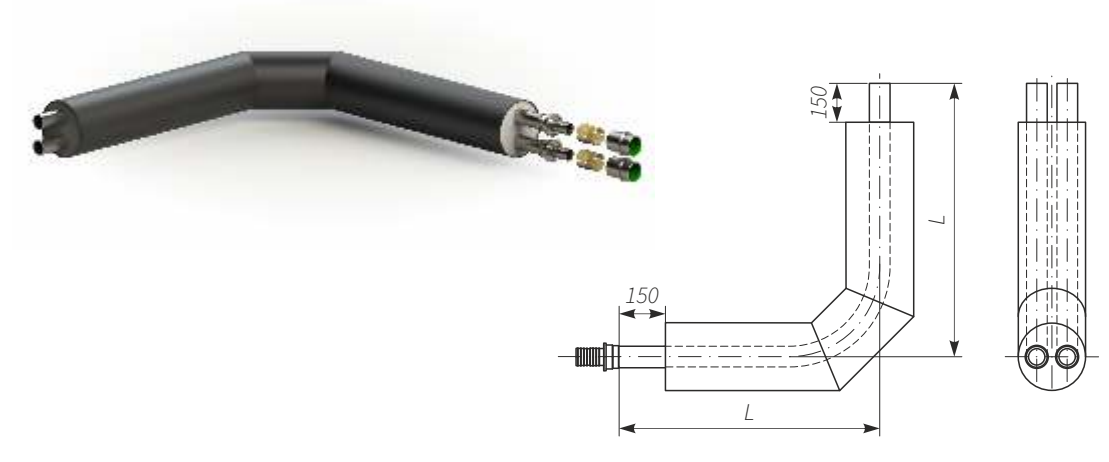

Overview

Table A3.6

Pos	Item	L, mm	Weight, kg	Art.-No.
1	50+50/160	1000	20.50	236102050050
2	63+63/180	1000	26.00	236102063063
3	75+75/200	1000	33.30	236102075075

A3.7. FibreFlex Pro Y-Connection UNO to DUO Pre-Insulated

General

Application:	for FibreFlex pro DUO pipe connection with two single FibreFlex pipes
Service pipe:	steel ST 37.0
Insulation:	foamed polyurethane (PUR)
Jacket pipe:	HD-PE
Thermal conductivity:	≤ 0.027 W/mK at 50°C

Design

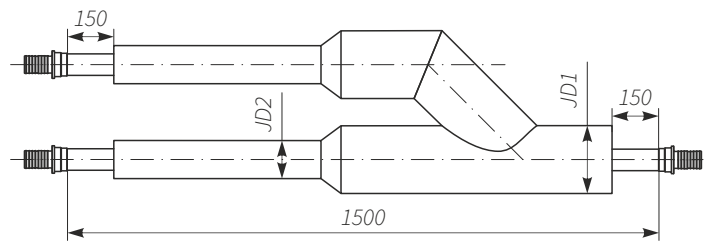

Overview

Table A3.7

Pos	Service pipe dimension	JD1, mm	JD2, mm	Weight, kg	Art.-No.
1	50	160	110	22.80	275102050050
2	63	180	125	30.10	275102063063
3	75	200	140	40.40	275102075075

A4. Products to resist water ingress and provide heat insulation

Overview

To protect and seal the ends of the FibreFlex Pro pipe ends from water, Heat Shrink End Caps shall be installed.

It is important to provide adequate insulation at every FibreFlex Pro connection when buried underground, as ground water ingress into the joint insulation will have a critical effect on the fittings corrosion resistance and will increase the system heat loss.

To insulate the FibreFlex Pro Press Coupler or the joints to the FibreFlex Pro pre-insulated fittings, a Heat Shrink Sleeve should be used. The flame from a gas burner is used to warm the Heat Shrink Sleeve, which shrinks onto the FibreFlex Pro jacket. Additional heat shrink bands are installed above the ends of the Heat Shrink Sleeve and provide increased leakage protection.

For future connections to FibreFlex Pro pipeline, a pre-insulated T-Branch with a blind outlet or additional valve can be installed. To provide heat insulation to the Dead End a Heat Shrink Sleeve shall be installed and insulated with PUR Liquid Components.

Types of products

Table A4

Name	Purpose	Description
End Cap Heat Shrink	for water insulation of FibreFlex Pro pipe ends	A4.1
End Cap Heat Shrink DUO		A4.2
Sleeve Heat Shrink	for insulation of FibreFlex Pro Press Couplers and joints to FibreFlex Pro pre-insulated connectors	A4.3
Dead End Sleeve Heat Shrink	for insulation of dead branch end for future connections to FibreFlex Pro pipeline	A4.4
PUR Liquid Components	for heat insulation of all types of joints, for pouring into Sleeves and Shells after their installation	A4.5

A4.1. End Cap Heat Shrink

General

Application: for FibreFlex Pro insulation pipe end seal
Material: cross-linked polyethylene PEX-c

Design



Overview

Table A4.1

Pos	Item	Service pipe dimension	Jacket pipe dimension	Weight, kg	Art.-No.
1	25-50/76-126	25-50	91-126	0.17	3575200
2	60-76/125-142	63-75	126-142	0.19	3575600
3	60-90/160-182	75-90	162-182	0.22	3575900
4	89-114/160-225	110	162-225	0.25	3576000
5	75-140/160-250	90-160	162-225	0.18	3576200

A4.2. End Cap Heat Shrink DUO

General

Application: for FibreFlex Pro DUO insulation pipe end seal
Material: cross-linked polyethylene PEX-c

Design



Overview

Table A4.2

Pos	Item	Service pipe dimension	Jacket pipe dimension	Weight, kg	Art.-No.
1	(24-48)+(24-48)/135-200	(40+40)-(50+50)	142-182	0.21	3031300
2	(50-85)+(50-85)/175-250	(63+63)-(75+75)	182-225	0.23	3031350

A4.3. Sleeve Heat Shrink (incl. PUR liquid components)

General

Application: for the insulation of FibreFlex Pro Couplers and joints to FibreFlex Pro pre-insulated connectors

Sleeve material: PE-HD

PUR liquid components: polyol with penthane, isocyanate (in two separate plastic bottles)

Design

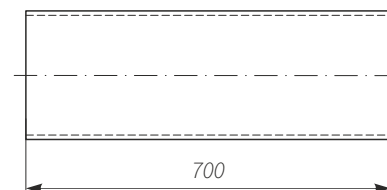

Overview

Table A4.3

Pos	Jacket pipe dimension	PUR Set	Weight, kg	Art.-No.
Straight				
1	111	2	1.32	3020520L
2	126	3	1.43	3020525L
3	142	4	1.55	3020530L
4	162	5	2.02	3020535L
5	182	6	2.22	3020545L
6	202	7	2.40	3020546L
7	225	8	3.11	3020547L
Reduced				
8	126/111	3	1.75	3030645L
9	142/111	4	1.79	3030660L
10	142/126	4	1.79	3030665L
11	162/111	5	2.10	3030670L
12	162/142	5	2.10	3030675L
13	182/142	6	2.40	3030680L
14	182/162	6	2.40	3030685L
15	202/182	6	2.64	3030695L
16	225/202	7	2.92	3030700L

A4.4. Dead End Heat Shrink (incl. PUR liquid components)

General

Application: for the insulation of dead branch end for future connections to FibreFlex Pro pipelines

Sleeve material: PE-HD

PUR liquid components: polyol with penthane, isocyanate (in two separate plastic bootles)

Design

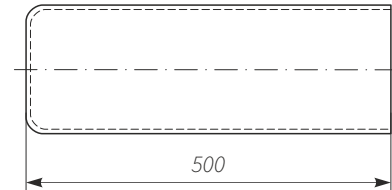

Overview

Table A4.4

Pos	Jacket pipe dimension	PUR Set	Weight, kg	Art.-No.
1	111	2	1.71	3578220
2	126	3	1.84	3578430
3	142	4	1.98	3578620
4	162	5	2.21	3578815
5	182	6	2.56	3578910
6	202	6	2.78	3579010
7	225	7	3.33	3579210

A4.5. PUR Liquid Components

General

Application: for FibreFlex Pro pipe joint insulation

Composition: polyol with penthane, isocyanate (in two separate plastic bootles)



Overview

Table A4.5

Pos	Packing size number	Polyol with penthane volume, L	Isocyanate volume, L	Weight, kg	Art.-No.
1	1	0.15	0.20	0.52	3810600
2	2	0.17	0.23	0.57	3810602
3	3	0.19	0.25	0.62	3810604
4	4	0.23	0.30	0.72	3810606
5	5	0.26	0.35	0.82	3810608
6	6	0.35	0.48	1.07	3810610
7	7	0.40	0.56	1.22	3810614
8	8	0.66	0.91	2.03	3810616
9	9	0.89	1.24	2.69	3810618

A5. Building entry accessories

Overview

Wall Sealing Rings should be used where the FibreFlex Pro pipe penetrates the wall of the building, this will prevent ground water entering the building, (ground water pressure resistance up to 0.5 bar).

Where the ground water level is high or in areas where there is a risk of flooding the Wall Compression Seal 80 shall be used (water pressure resistance up to 1 bar). Where there is additionally, a requirement to both seal the bore hole and for aesthetic reasons to cover gaps between the pipe and the bore hole, then the Wall Compression Seal 40, should be used.

Wall Compression Seals may be used in conjunction with a PVC Pipe Sleeve; this provides an increased level of wall compression seal tightness.

At the exposed end of the FibreFlex Pro pipe a Heat Shrink End Cap (see A4.1 and A4.2) shall be used to protect the pipe insulation; this will prevent ground water making contact with the FibreFlex Pro foam insulation.

Types products

ofTable A5

Name	Purpose	Description
Wall Sealing Ring	to prevent ground water entering the building at the FibreFlex Pro pipe wall penetration point (up to 0.5 bar pressure tightness)	A5.1
Wall Compression Seal 80	to prevent ground water entering the building at the FibreFlex Pro pipe wall penetration point (up to 1.0 bar pressure tightness)	A5.2
Wall Compression Seal 40		A5.3
PVC Pipe Sleeve	for increased Wall Compression Seal tightness	A5.4

A5.1. Wall Sealing Ring

General

Application: FibreFlex Pro pipe wall penetration sleeve, up to 0.5 bar pressure tightness
Material: neoprene

Design



Overview

Table A5.1

Pos	Jacket pipe dimension, mm	Weight, kg	Art.-No.
1	111	0.32	3560200
2	126	0.37	3560400
3	142	0.40	3560500
4	162	0.45	3560600
5	182	0.50	3560700
6	202	0.52	3560800
7	225	0.55	3560900

A5.2. Wall Compression Seal 80

General

Application: FibreFlex Pro pipe wall penetration sleeve, up to 1.0 bar pressure tightness
Material: steel, EPDM

Design



Overview

Table A5.2

Pos	Jacket pipe dimension, mm	Bore diameter, mm	Weight, kg	Art.-No.
1	111	200	3.06	977000200111
2	126	200	2.40	977000200126
3	142	200	2.10	977000200142
4	162	250	3.76	977000250162
5	182	250	3.21	977000250182
6	202	250	2.30	977000250202
7	225	350	7.97	977000350225

A5.3. Wall Compression Seal 40

General

Application: used to seal the annular gap between the pipe and the bore hole
Material: steel, EPDM

Design



Overview

Table A5.3

Pos	Jacket pipe dimension, mm	Bore diameter, mm	Weight, kg	Art.-No.
1	111	200	2.40	979000200111
2	126	200	2.40	979000200126
3	142	200	1.90	979000200142
4	162	250	2.74	979000250162
5	182	250	2.18	979000250182
6	202	250	1.64	979000250202
7	225	350	5.74	979000350225

A5.4. PVC Pipe Sleeve

General

Application: bore hole sleeve for increased Wall Compression Seal tightness
Material: PVC

Design



Overview

Table A5.4

Pos	Bore diameter, mm	Outside diameter, mm	Weight, kg	Art.-No.
1	150	158	1.24	978000158150
2	200	210	1.67	977000210200
3	250	280	6.22	977000280200

A6. Pressure Loss

Overview

When estimating the pressure loss through a FibreFlex Pro pipe, Fig. A6 shall be used.

Procedure:

- 1) Mark the required flow quantity or heat capacity on the vertical axis.
- 2) Draw a horizontal line on the diagram corresponding to this value.
- 3) Mark where this horizontal line crosses the orange lines corresponding to the FibreFlex Pro carrier pipe dimensions.
- 4) Draw a vertical line from this intersection to the horizontal axis. Read off the pressure loss on the horizontal axis.

FibreFlex Pro Pressure Loss Diagram

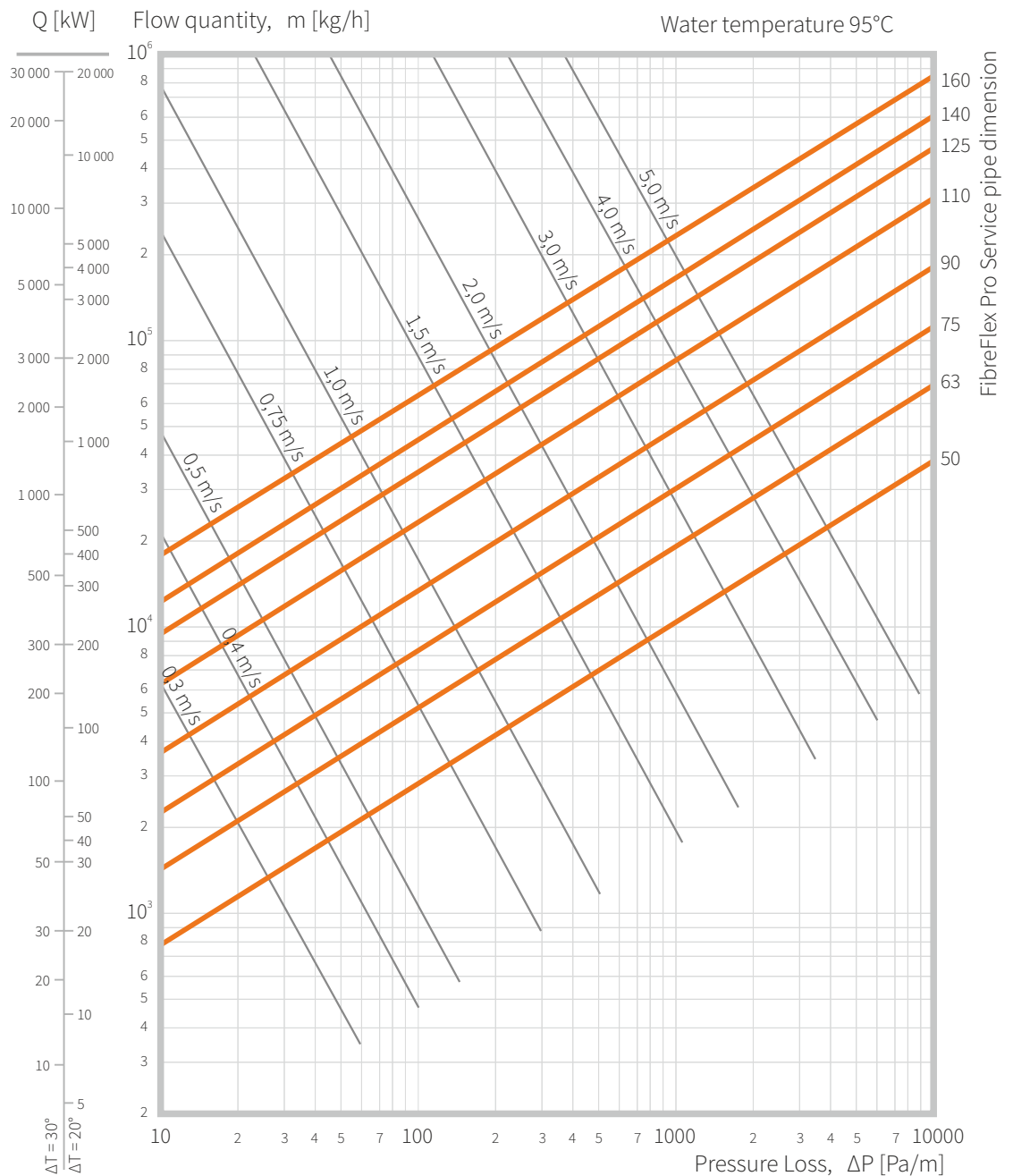

Fig. A6

A7. Heat Loss

Heat losses is calculated for a 1 meter length of FibreFlex Pro pipe network consisting of supply and return pipelines (two FibreFlex Pro single pipes with a 100 mm distance between), buried in ground with normal conditions, are shown in table A7.1.

Heat losses calculated for a 1 meter of FibreFlex Pro DUO pipe buried in the ground with normal conditions, are shown in Table A7.2.

Conditions

Cover above pipe	0.8 m
Ground temperature	+ 10°C
Soil thermal conductivity	1.0 W/mK
PUR insulation thermal conductivity	0.021 W/mK
Service pipe thermal conductivity	0.38 W/mK

$$q = K \cdot (\bar{t} - t_g)$$

where

$$\bar{t} = \frac{t_s + t_r}{2} \text{ - average operating temperature, } ^\circ\text{C};$$

K - Heat transfer coefficient, W/mK;

t_s - Supply operating temperature, °C;

t_r - Return operating temperature, °C;

t_g - Ground temperature, °C.

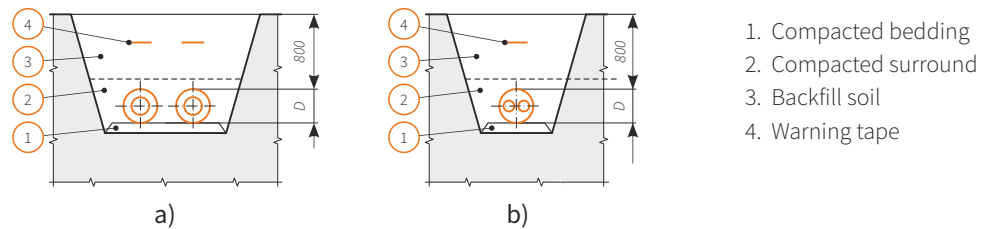

Fig. A7

FibreFlex Pro heat losses for 1 m network (total heat losses for supply and return pipelines)

Table A7.1

FibreFlex Pro pipe dimension	K, W/mK	q, W/m				
		Average operating temperature, \bar{t} , °C				
		60	70	80	90	100
50/111	0.306	15.31	18.37	21.43	24.49	27.55
63/126	0.323	16.13	19.36	22.58	25.81	29.03
75/142	0.345	17.27	20.72	24.17	27.62	31.08
90/162	0.373	18.63	22.36	26.09	29.81	33.54
110/162	0.411	20.55	24.66	28.77	32.88	36.99
125/182	0.434	21.72	26.06	30.40	34.75	39.09
140/202	0.509	25.43	30.52	35.61	40.70	45.78
160/225	0.528	26.42	31.71	36.99	42.27	47.56

FibreFlex Pro DUO heat losses for 1 m network

Table A7.2

FibreFlex Pro DUO pipe dimension	K, W/mK	q, W/m				
		Average operating temperature, \bar{t} , °C				
		60	70	80	90	100
50+50/162	0.194	9.68	11.61	13.55	15.48	17.42
63+63/182	0.211	10.53	12.63	14.74	16.84	18.95
75+75/202	0.235	11.73	14.08	16.42	18.77	21.12

Heat losses, calculated for a 1 meter length of FibreFlex pipe pipelines (single pipe network) buried in ground with normal conditions, are shown in Table A7.3.

Conditions

Cover above pipe	0.8 m
Ground temperature	+ 10°C
Soil thermal conductivity	1.0 W/mK
PUR insulation thermal conductivity	0.021 W/mK
Service pipe thermal conductivity	0.38 W/mK

$$q = K \cdot (\bar{t} - t_g)$$

where

$$\bar{t} = \frac{t_s + t_r}{2} \text{ - Average operating temperature, } ^\circ\text{C};$$

t - Operating temperature, °C;

K - Heat transfer coefficient, W/mK;

t_g - Ground temperature, °C.

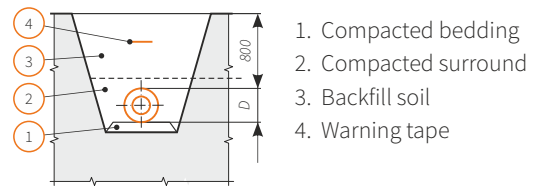

Fig. A8

FibreFlex heat losses for 1 m single FibreFlex pipeline

Table A7.3

FibreFlex UNO pipe dimension	K, W/mK	q, W/m				
		Average operating temperature, \bar{t} , °C				
		60	70	80	90	100
50/111	0.161	8.07	9.68	11.30	12.91	14.53
63/126	0.170	8.51	10.22	11.92	13.62	15.33
75/142	0.183	9.13	10.96	12.78	14.61	16.44
90/162	0.198	9.88	11.85	13.83	15.80	17.78
110/162	0.219	10.93	13.12	15.30	17.49	19.68
125/182	0.231	11.57	13.88	16.19	18.50	20.82
140/202	0.274	13.70	16.44	19.18	21.92	24.66
160/225	0.285	14.23	17.07	17.07	22.76	25.61

Heat loss comparison to conventional steel pre-insulated pipes

The FibreFlex Pro pipes are insulated in one continuous manufacturing process using a CFC-free bonded polyurethane foam with an outstanding thermal conductivity value of $\lambda \leq 0.021 \text{ W/mK}$ at 50°C .

As the insulation layer has a lower thermal conductivity than conventional pre-insulated steel pipes ($\lambda = 0.027 \text{ W/mK}$), in diameters up to 80 mm, FibreFlex Pro heat loss is lower than insulation series S3 pipes and in larger diameters, FibreFlex Pro heat loss is lower than series S2 pipes (see Fig. A9).

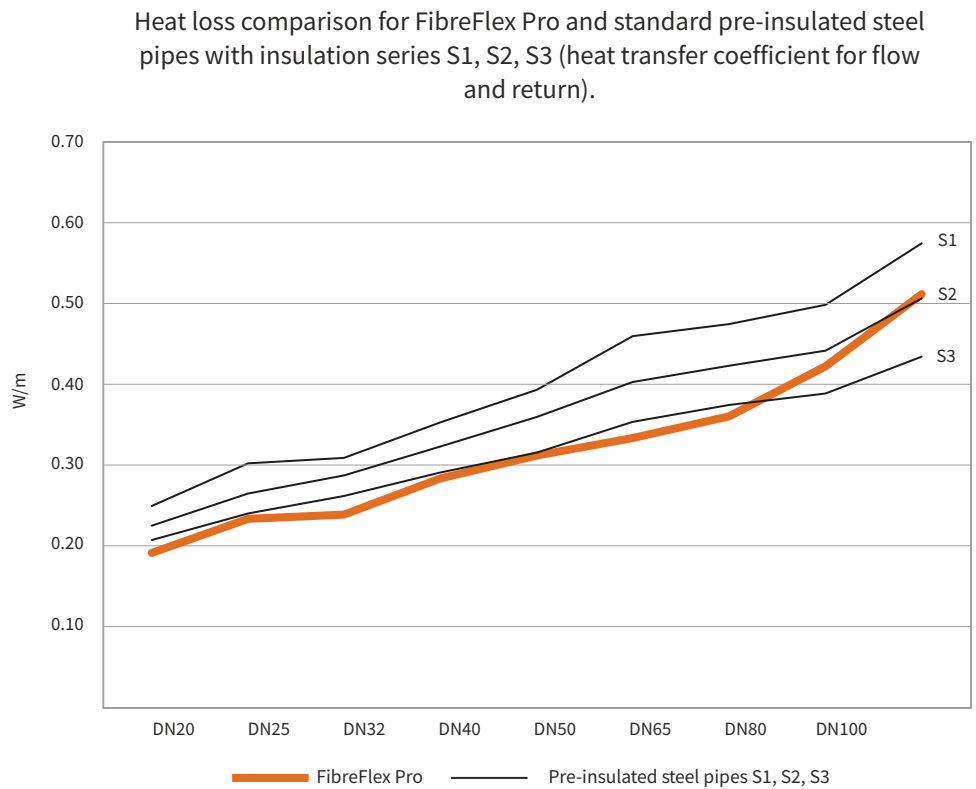

Fig. A9

FibreFlex Pro

Product Catalogue



Radius-Kelit Infrastructure Gesellschaft m.b.H.

phone +43 (0)7435/93080
fax +43 (0)7435/93080-218
e-mail office@radius-kelit.com
address Gollensdorf 24 A-4300 St. Valentin
web www.radius-kelit.com



Authorized Dealer:
Biomass Systems Supply
P.O. Box 1835 * Chico, CA 95927
Toll Free: 877-474-5521
Office: 530-893-2444
www.BiomassSystemsSupply.com